

Bu Resim MESA OTO ELEKTRİK LTD.ŞTİ'nin malıdır. Şirket Yetkililerinin izni olmaksızın kopya edilemez, üzerinde değişiklik yapılamaz. This image MESA AUTO ELECTRIC LTD.'s are property. Can not be copied without the consent of the company authorized, any changes can be made.

PARÇA KODU PART CODE	PARÇA ADI PART NAME	ERKEK TERMİNAL MALE TERMINAL	a ÖLÇÜSÜ (AYAR) a MEASURE (SET)	s ÖLÇÜSÜ (KALINLIK) s MEASURE (THICKNESS)	Malzeme Material	Kaplama / Coating		
						SN	AG	Nİ
TD 2102.40 RP	MİKRO DİŞİ FİŞ 2.8 (0.40) =RP=	0.40	0.30±0.05	-----	(CuZn30) Pirinç / Brass	-	-	-
TD 2102.40 RPK	MİKRO DİŞİ FİŞ 2.8 (0.40) =RPK=	0.40	0.30±0.05	-----	(CuZn30) Pirinç / Brass	+	-	-
TD 2102.50 DP	MİKRO DİŞİ FİŞ 2.8 (0.50) =DP=	0.50	0.40±0.05	-----	(CuZn30) Pirinç / Brass	-	-	-
TD 2102.50 RP	MİKRO DİŞİ FİŞ 2.8 (0.50) =RP=	0.50	0.40±0.05	-----	(CuZn30) Pirinç / Brass	-	-	-
TD 2102.50 RPK	MİKRO DİŞİ FİŞ 2.8 (0.50) =RPK=	0.50	0.40±0.05	-----	(CuZn30) Pirinç / Brass	+	-	-
TD 2102.60 RP	MİKRO DİŞİ FİŞ 2.8 (0.60) =RP=	0.60	0.50±0.05	-----	(CuZn30) Pirinç / Brass	-	-	-
TD 2102.60 RPK	MİKRO DİŞİ FİŞ 2.8 (0.60) =RPK=	0.60	0.50±0.05	-----	(CuZn30) Pirinç / Brass	+	-	-
TD 2102.70 RP	MİKRO DİŞİ FİŞ 2.8 (0.70) =RP=	0.70	0.60±0.05	-----	(CuZn30) Pirinç / Brass	-	-	-
TD 2102.70 RPK	MİKRO DİŞİ FİŞ 2.8 (0.70) =RPK=	0.70	0.60±0.05	-----	(CuZn30) Pirinç / Brass	+	-	-
TD 2102.80 DP	MİKRO DİŞİ FİŞ 2.8 (0.80) =DP=	0.80	0.70±0.05	-----	(CuZn30) Pirinç / Brass	-	-	-
TD 2102.80 RP	MİKRO DİŞİ FİŞ 2.8 (0.80) =RP=	0.80	0.70±0.05	-----	(CuZn30) Pirinç / Brass	-	-	-
TD 2102.80 RPK	MİKRO DİŞİ FİŞ 2.8 (0.80) =RPK=	0.80	0.70±0.05	-----	(CuZn30) Pirinç / Brass	+	-	-

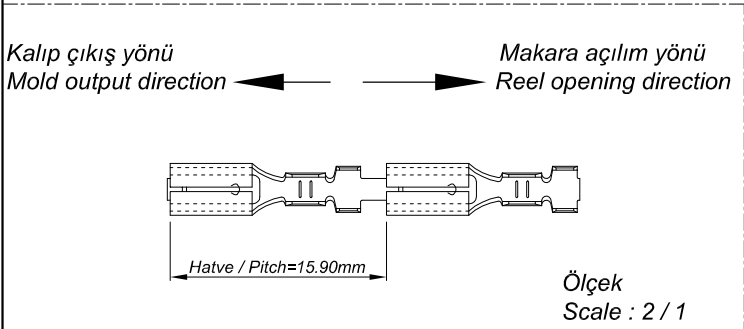
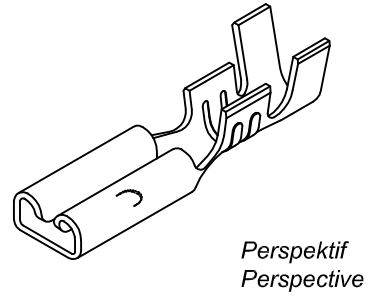
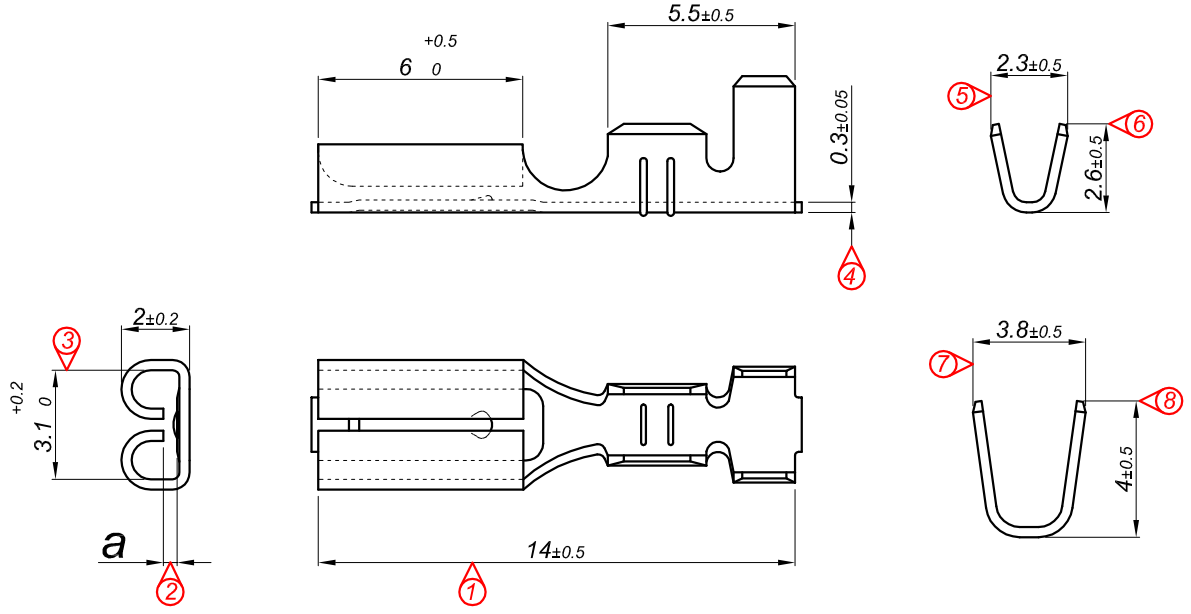

Kablo Kesiti
Wire Section : 0.5 - 1 mm²

Resim üzerinden ölçü almayınız
do not measure on drawing

Tarih / Date	01.06.2011	İmza / Signature	Ölçek / Scale			
Çizen / Desing	M.Yağcı		5 / 1	01	3.5 Olan Pvc Sıkan Ayak Yüksekliği 4 Olarak Değiştirildi.	03.02.2015
Onay / Approval	S.Gölcük			No	Değişiklik / Revision	Tarih/Date



Parça Adı:
Part Name

MİKRO DİŞİ FİŞ 2.8

Parça Kodu:
Part Code

TD 2102