

Bu Çizim MESA OTO ELEKTRİK LTD.ŞTİ'nin malıdır. Şirket Yetkililerinin izni olmaksızın kopya edilemez, üzerinde değişiklik yapılamaz.
This Drawing MESA AUTO ELECTRIC LTD 's are property. Can not be copied without the consent of the company authorized, any changes can be made.

PARÇA KODU PART CODE	PARÇA ADI PART NAME	s ÖLÇÜSÜ (KALINLIK) s MEASURE (THICKNESS)	Malzeme Material	Kaplama / Coating		
				SN	AG	Ni
TK 2809 RP	SIRALI KURT AĞZI 1.5 (2.5-4 mm ²) =RP=	0.25±0.03	(CuZn30) Pirinç / Brass	-	-	-
TK 2809 RPK	SIRALI KURT AĞZI 1.5 (2.5-4 mm ²) =RPK=	0.25±0.03	(CuZn30) Pirinç / Brass	+	-	-
TK 2809.30 RP	SIRALI KURT AĞZI 1.5 (2.5-4 mm ²) =RP=	0.30±0.03	(CuZn30) Pirinç / Brass	-	-	-
TK 2809.30 RPK	SIRALI KURT AĞZI 1.5 (2.5-4 mm ²) =RPK=	0.30±0.03	(CuZn30) Pirinç / Brass	+	-	-

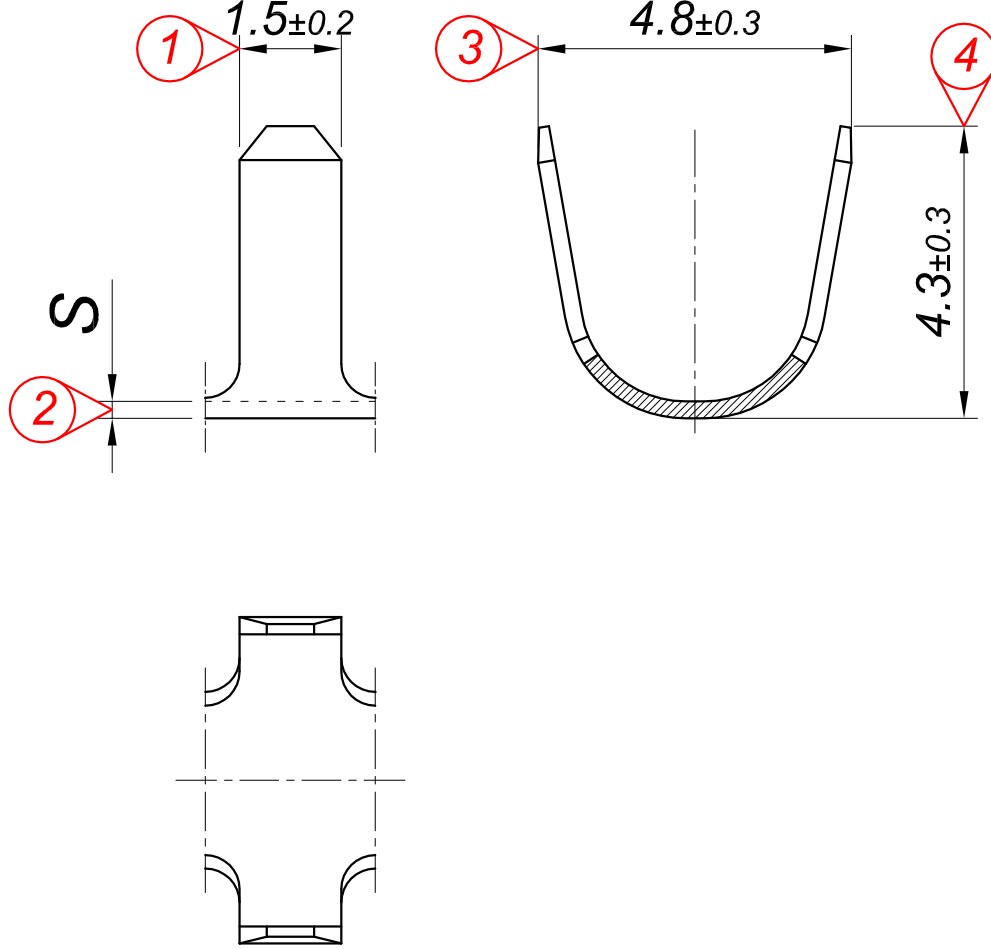

Kablo Kesiti

Wire Section : 2.50 - 4 mm²

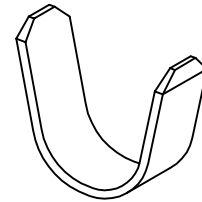
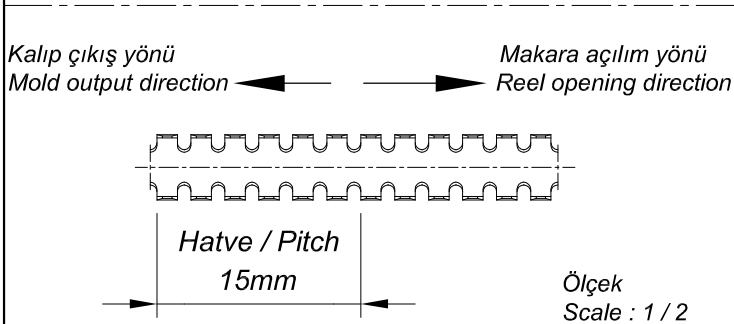

Perspektif
Perspective

Resim üzerinden ölçü almayınız
do not measure on drawing

Tarih / Date	20.08.2015	İmza / Signature	Ölçek / Scale			
Çizen / Desing	M.Yağcı		10 / 1			
Onay / Approval	S.Gölcük		No		Değişiklik / Revision	Tarih/Date
	Parça Adı: Part Name	SIRALI KURT AĞZI 1.5 (2.5-4 mm ²)			Parça Kodu: Part Code	TK 2809