

PARÇA KODU PART CODE	PARÇA ADI PART NAME	s ÖLÇÜSÜ (KALINLIK) s MEASURE (THICKNESS)	Malzeme Material	Kaplama / Coating		
				SN	AG	Ni
TŞ 2408 DP	1 NO 2.TERMİNAL Ø3.2 =DP=	-----	(CuZn30) Pirinç / Brass	-	-	-
TŞ 2408 RP	1 NO 2.TERMİNAL Ø3.2 =RP=	-----	(CuZn30) Pirinç / Brass	-	-	-
TŞ 2408 RPK	1 NO 2.TERMİNAL Ø3.2 =RPK=	-----	(CuZn30) Pirinç / Brass	+	-	-
TŞ 2408 RÇN	1 NO 2.TERMİNAL Ø3.2 =RÇN=	-----	Paslanmaz Sac(430)	-	-	+

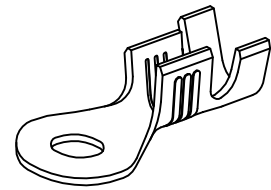

Perspektif
Perspective

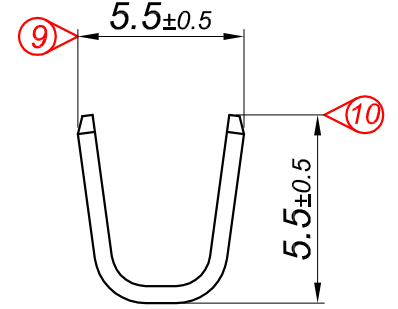
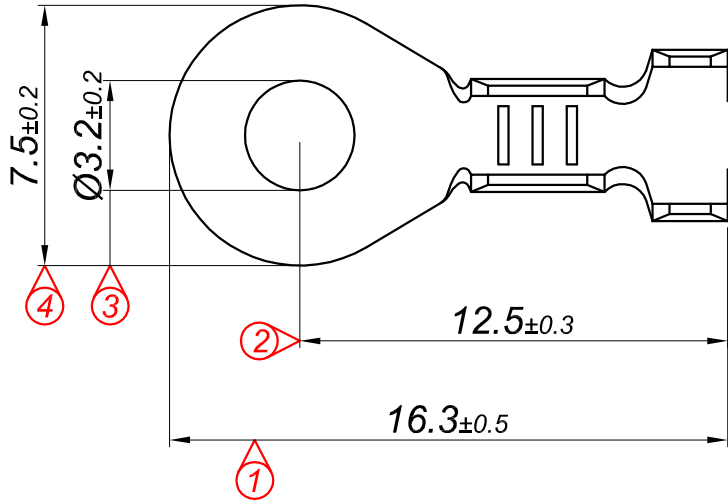
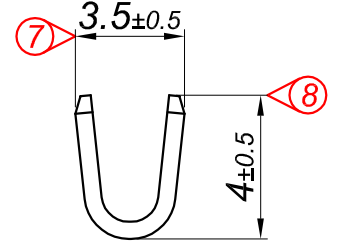
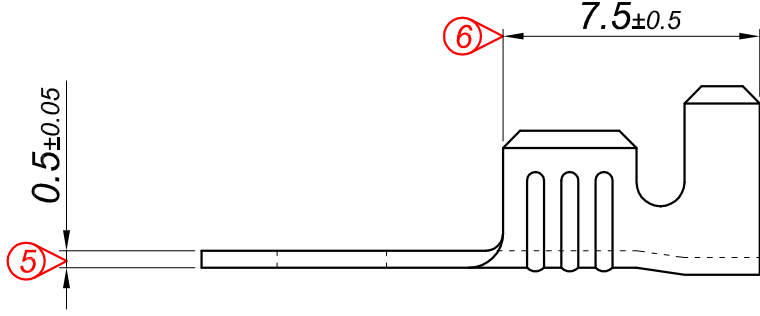
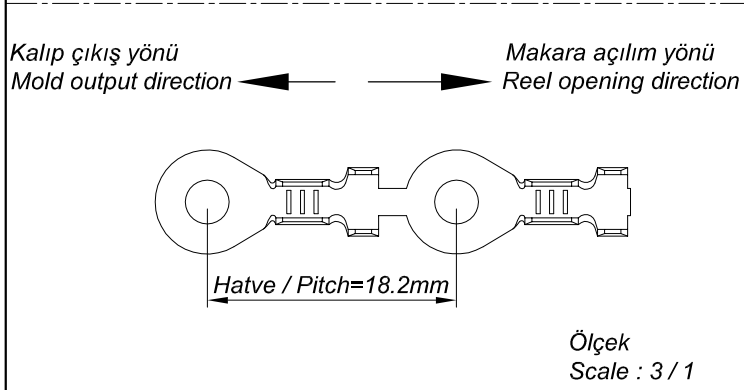

Kablo Kesiti
Wire Section : 1 - 2.50 mm²

Resim üzerinden ölçü almayınız
do not measure on drawing

Tarih / Date	19.07.2013	İmza /Signature	Ölçek /Scale			
Çizen / Desing	M.Yağcı		5 / 1	01	ÇİFTLİ KALIP YAPILMIŞTIR.	30.11.2015
Onay / Approval	S.Gölcük			No	Değişiklik / Revision	Tarih/Date



Parça Adı:
Part Name

1 NO 2.TERMİNAL Ø3.2

Parça Kodu:
Part Code

TŞ 2408