

Bu Resim MESA OTO ELEKTRİK LTD.ŞTİ'nin malıdır. Şirket Yetkililerinin izni olmaksızın kopya edilemez, üzerinde değişiklik yapılamaz.
This image MESA AUTO ELECTRIC LTD 's are property. Can not be copied without the consent of the company authorized, any changes can be made.

PARÇA KODU PART CODE	PARÇA ADI PART NAME	s ÖLÇÜSÜ (KALINLIK) s MEASURE (THICKNESS)	Malzeme Material	Kaplama / Coating		
				SN	AG	Nİ
TŞ 2409 DP	1 NO 2.TERMİNAL Ø3.5 =DP=	-----	(CuZn30) Pirinç / Brass	-	-	-
TŞ 2409 RP	1 NO 2.TERMİNAL Ø3.5 =RP=	-----	(CuZn30) Pirinç / Brass	-	-	-
TŞ 2409 RPK	1 NO 2.TERMİNAL Ø3.5 =RPK=	-----	(CuZn30) Pirinç / Brass	+	-	-
TŞ 2409 RÇN	1 NO 2.TERMİNAL Ø3.5 =RÇN=	-----	Paslanmaz Sac(430)	-	-	+

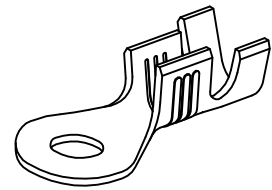

Perspektif
Perspective

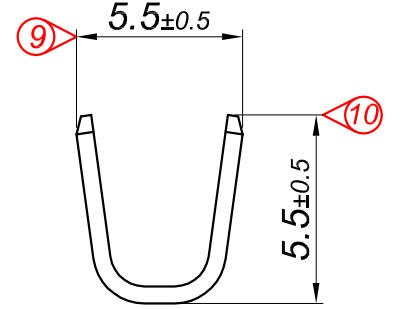
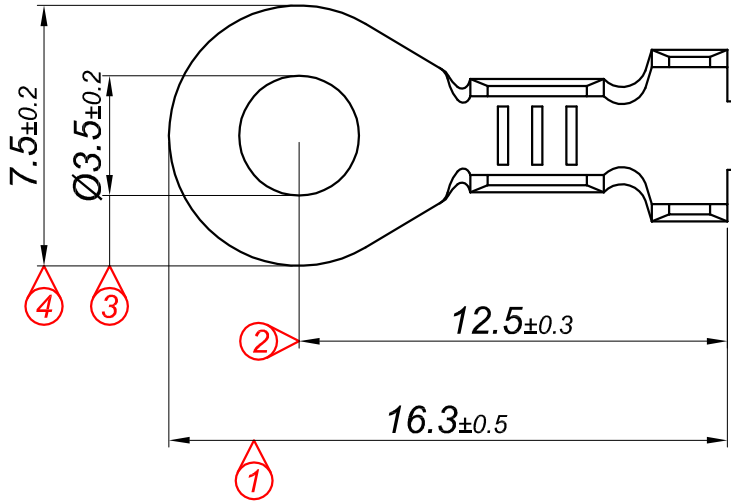
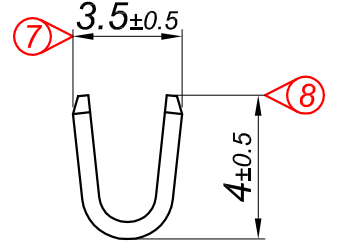
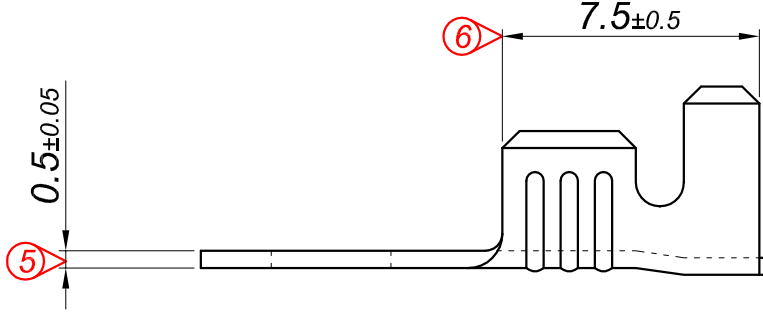
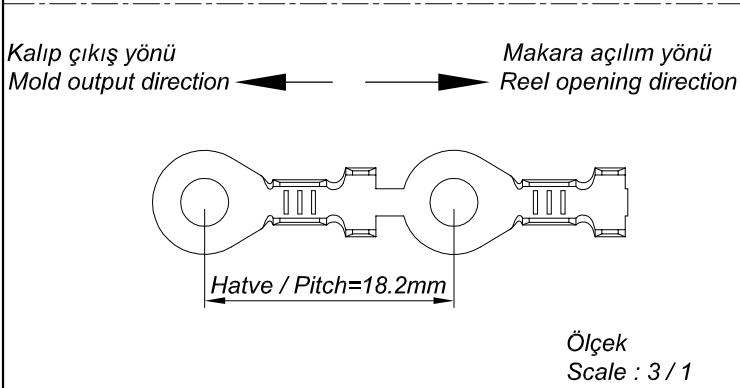

Kablo Kesiti
Wire Section : 1 - 2.50 mm²

Resim üzerinden ölçü almayınız
do not measure on drawing

Tarih / Date	19.07.2013	İmza /Signature	Ölçek /Scale			
Çizen / Desing	M.Yağcı		5 / 1	01	ÇİFTLİ KALIP YAPILMIŞTIR.	30.11.2015
Onay / Approval	S.Gölcük			No	Değişiklik / Revision	Tarih/Date



Parça Adı:
Part Name

1 NO 2.TERMİNAL Ø3.5

Parça Kodu:
Part Code

TŞ 2409