

Bu Resim MESA OTO ELEKTRİK LTD.ŞTİ'nin malıdır. Şirket Yetkililerinin izni olmaksızın kopya edilemez, üzerinde değişiklik yapılamaz. This image MESA AUTO ELECTRIC LTD 's are property. Can not be copied without the consent of the company authorized, any changes can be made.

PARÇA KODU PART CODE	PARÇA ADI PART NAME	s ÖLÇÜSÜ (KALINLIK) s MEASURE (THICKNESS)	Malzeme Material	Kaplama / Coating		
				SN	AG	Nİ
TŞ 2411 DP	1 NO 2.TERMINAL Ø5.2 =DP=	-----	(CuZn30) Pirinç / Brass	-	-	-
TŞ 2411 RP	1 NO 2.TERMINAL Ø5.2 =RP=	-----	(CuZn30) Pirinç / Brass	-	-	-
TŞ 2411 RPK	1 NO 2.TERMINAL Ø5.2 =RPK=	-----	(CuZn30) Pirinç / Brass	+	-	-
TŞ 2411 RÇN	1 NO 2.TERMINAL Ø5.2 =RÇN=	-----	Paslanmaz Sac(430)	-	-	+

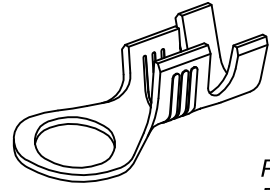
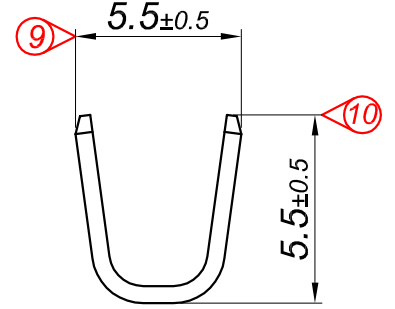
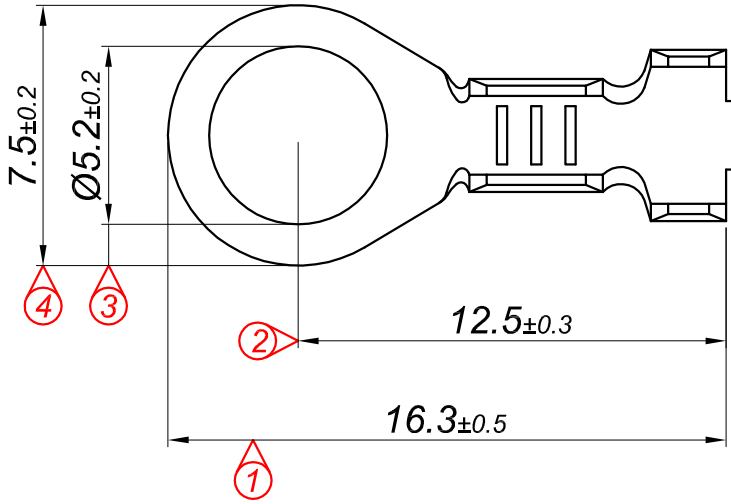
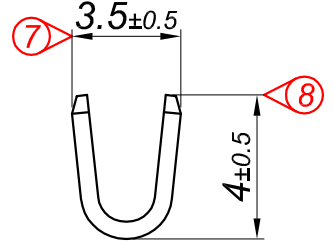
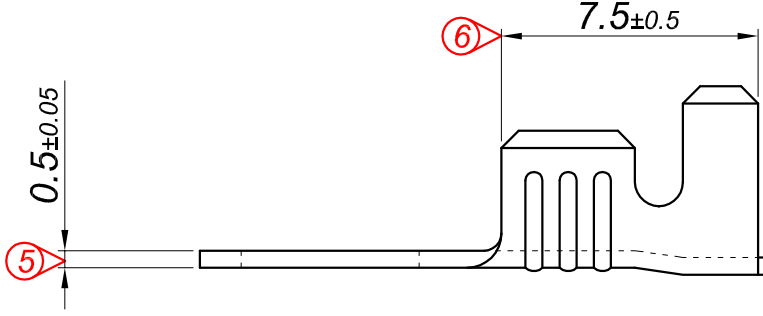

Perspektif
Perspective

Kalıp çıkış yönü
Mold output direction ← → Makara açılım yönü
Reel opening direction

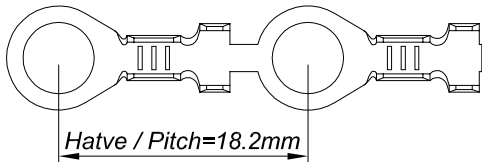

Ölçek
Scale : 3 / 1

Kablo Kesiti
Wire Section : 1 - 2.50 mm²

Resim üzerinden ölçü almayınız
do not measure on drawing

Tarih / Date	19.07.2013	İmza /Signature	Ölçek /Scale		
Çizen / Desing	M.Yağcı		5 / 1	01	ÇİFTLİ KALIP YAPILMIŞTIR.
Onay / Approval	S.Gölcük			No	Değişiklik / Revision
					30.11.2015 Tarih/Date



Parça Adı:
Part Name

1 NO 2.TERMINAL Ø5.2

Parça Kodu:
Part Code

TŞ 2411