

PARÇA KODU PART CODE	PARÇA ADI PART NAME	s ÖLÇÜSÜ (KALINLIK) s MEASURE (THICKNESS)	Malzeme Material	Kaplama / Coating		
				SN	AG	Nİ
TŞ 2416.38 DP	2.5 NO KABLO UÇ Ø6.2 =DP=	0.38±0.05	(CuZn30) Pirinç / Brass	-	-	-
TŞ 2416.38 RP	2.5 NO KABLO UÇ Ø6.2 =RP=	0.38±0.05	(CuZn30) Pirinç / Brass	-	-	-
TŞ 2416.45 DP	2.5 NO KABLO UÇ Ø6.2 =DP=	0.45±0.05	(CuZn30) Pirinç / Brass	-	-	-
TŞ 2416.45 RP	2.5 NO KABLO UÇ Ø6.2 =RP=	0.45±0.05	(CuZn30) Pirinç / Brass	-	-	-
TŞ 2416.45 RPK	2.5 NO KABLO UÇ Ø6.2 =RPK=	0.45±0.05	(CuZn30) Pirinç / Brass	+	-	-
TŞ 2416.50 DP	2.5 NO KABLO UÇ Ø6.2 =DP=	0.50±0.05	(CuZn30) Pirinç / Brass	-	-	-
TŞ 2416.50 DÇN	2.5 NO KABLO UÇ Ø6.2 =DÇN=	0.50±0.05	Paslanmaz / Stainless Steel (430)	-	-	+
TŞ 2416.50 RP	2.5 NO KABLO UÇ Ø6.2 =RP=	0.50±0.05	(CuZn30) Pirinç / Brass	-	-	-
TŞ 2416.50 RPK	2.5 NO KABLO UÇ Ø6.2 =RPK=	0.50±0.05	(CuZn30) Pirinç / Brass	+	-	-
TŞ 2416.50 RÇN	2.5 NO KABLO UÇ Ø6.2 =RÇN=	0.50±0.05	Paslanmaz / Stainless Steel (430)	-	-	+

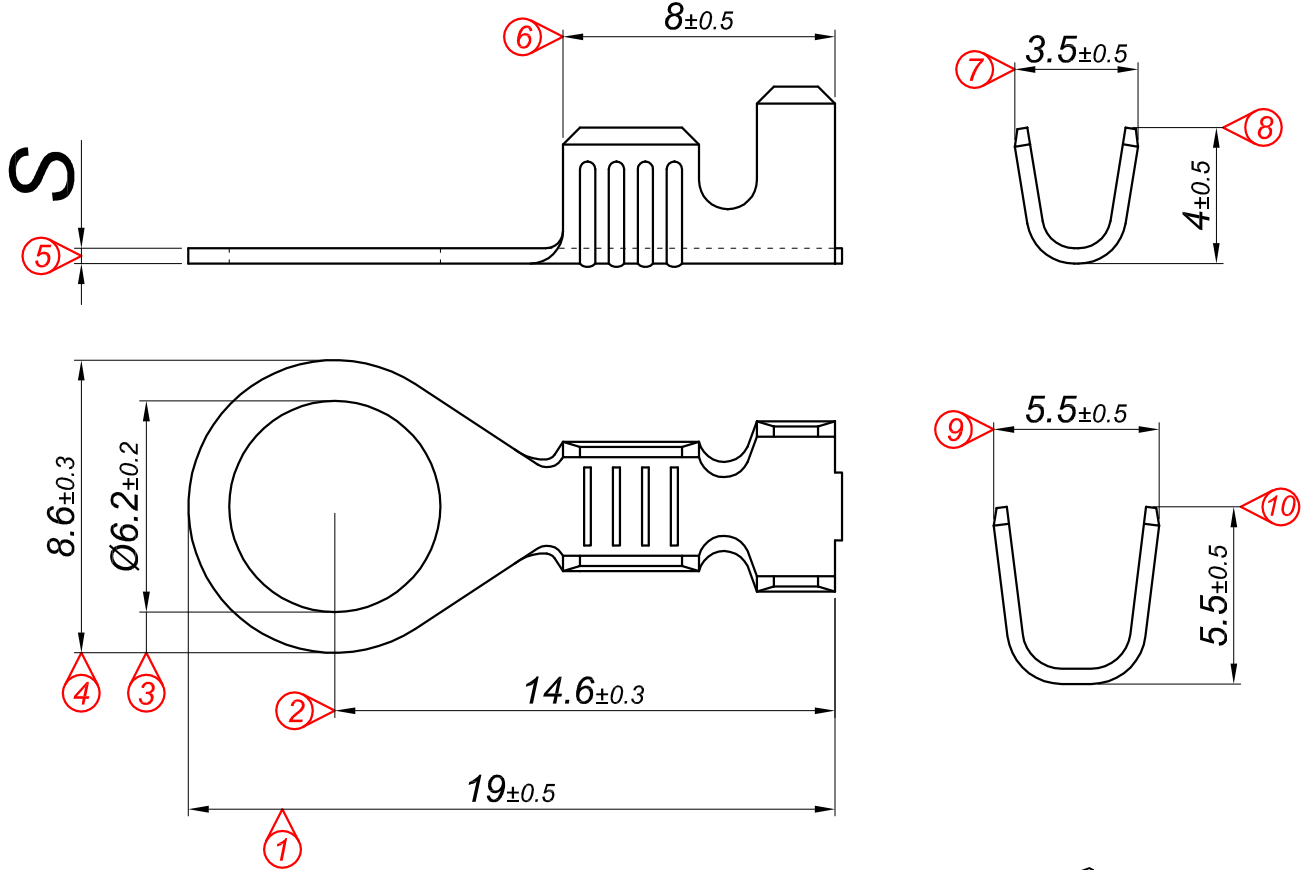

Kalıp çıkış yönü  
Mold output direction

Makara açılım yönü  
Reel opening direction

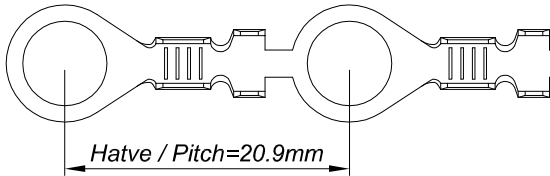

Ölçek  
Scale : 2 / 1

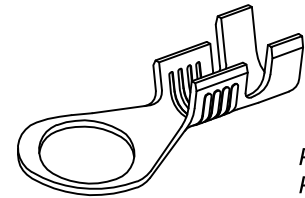

Perspektif  
Perspective

Kablo Kesiti  
Wire Section : 1 - 2.50 mm<sup>2</sup>

Resim üzerinden ölçü almayınız  
do not measure on drawing

Tarih / Date	19.07.2013	İmza /Signature	Ölçek /Scale			
Çizen / Desing	M.Yağcı		5 / 1			
Onay / Approval	S.Gölcük		No		Değişiklik / Revision	Tarih/Date
	Parça Adı: Part Name	2.5 NO KABLO UCU Ø6.2			Parça Kodu: Part Code	TŞ 2416