

Bu Resim MESA OTO ELEKTRİK LTD.ŞTİ'nin malıdır. Şirket Yetkilerinin izni olmaksızın kopya edilemez, üzerinde değişiklik yapılamaz.  
This image MESA AUTO ELECTRIC LTD.'s are property. Can not be copied without the consent of the company authorized, any changes can be made.

PARÇA KODU PART CODE	PARÇA ADI PART NAME	s ÖLÇÜSÜ (KALINLIK) s MEASURE (THICKNESS)	Malzeme Material	Kaplama / Coating		
				SN	AG	Nİ
TŞ 2466 DP	1 NO 2.TERMİNAL Ø2.7 K.A. =DP=	-----	(CuZn30) Pirinç / Brass	-	-	-
TŞ 2466 RP	1 NO 2.TERMİNAL Ø2.7 K.A. =RP=	-----	(CuZn30) Pirinç / Brass	-	-	-
TŞ 2466 RPK	1 NO 2.TERMİNAL Ø2.7 K.A. =RPK=	-----	(CuZn30) Pirinç / Brass	+	-	-
TŞ 2466 RÇN	1 NO 2.TERMİNAL Ø2.7 K.A. =RÇN=	-----	Paslanmaz Sac(430)	-	-	+

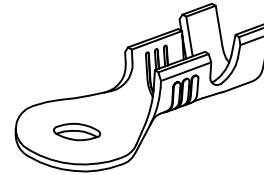
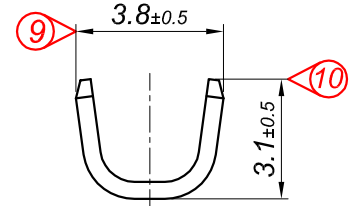
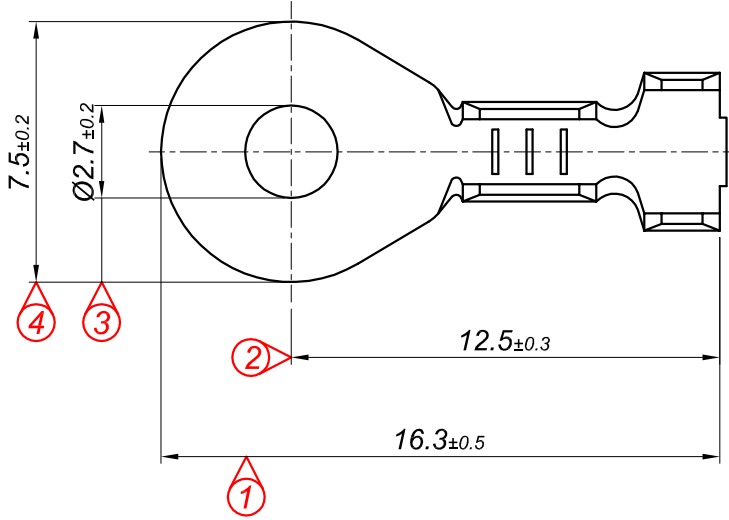
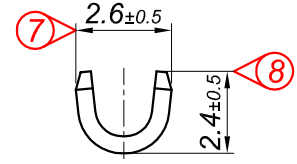
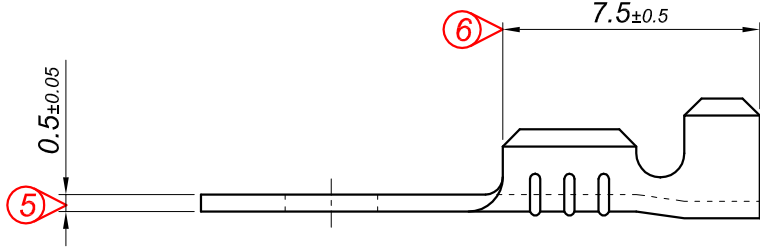

Perspektif  
Perspective

Kalıp çıkış yönü  
Mold output direction

Makara açılım yönü  
Reel opening direction

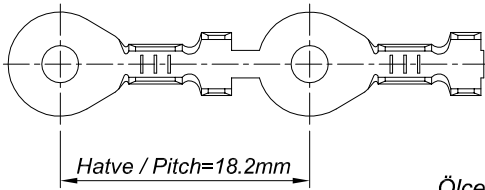

Kablo Kesiti

Wire Section : 0.25 - 0.50 mm<sup>2</sup>

Resim üzerinden ölçü almayınız  
do not measure on drawing

Tarih / Date	07.12.2014	İmza /Signature	Ölçek /Scale			
Çizen / Desing	M.Yağcı					
Onay / Approval	S.Gölcük		5 / 1	No	Değişiklik / Revision	Tarih/Date
	Parça Adı: Part Name	1 NO 2.TERMİNAL KÜÇÜK AYAK Ø2.7			Parça Kodu: Part Code	TŞ 2466