

FEMALE TERMINALS

TD 2114

Description/Tanım

TIRNAKLI DIŞI FİŞ 6.3

Wire section range (mm²)

1.00 - 2.50

Kablo kesit aralığı

Materials & Temperature

Malzeme ve Sıcaklıkları

Part no Ürün no	Material Malzeme	Coating Kaplama	Max. Temp. (°C) Max. Sıcaklık
TD 2114 RP	Brass / Pirinç	Naturel	110°C
TD 2114 RPK	Brass / Pirinç	Tin / Kalay	120°C
TD 2114 RPG	Brass / Pirinç	Silver / Gümüş	130°C
TD 2114 RFB	Bronze / Bronz	Unplated	120°C
TD 2114 RFBK	Bronze / Bronz	Tin / Kalay	130°C
TD 2114 RÇN	Steel / Çelik	Nickel/Nikel	300°C

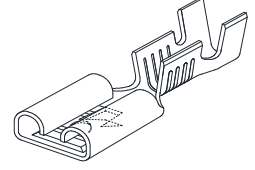

Material thickness (S) (mm)

0,28 / 0,30 / 0,35 / 0,38

Malzeme kalınlığı

Compatible connectors

Konnektör Uyumluluğu

KE 3201 - 3202 - 3203 - 3204 - 3207 - 3208 - 3209 - 3210 - 3211 - 3212 - 3216 / KR 3701 - 3702 - 3703 - 3704 - 3705

Current Carrying Capacity /

Crimping parameters & Pull-out force

Akım Taşıma Kapasitesi /

Sıkma parametreleri ve çekme kuvveti

Max. (A)	Wire section (mm ² ±10%) Kablo kesiti	Conductor (±0.1) iletken		Insulator (±0.1) Yalıtkan	Pull-out force (N) Çıkma kuvveti
		Height/Yüks.(mm)	Width/Gen.(mm)	Width/Gen. (mm)	MESA min.
12	1,00	1,67	3,05	4,05	108
16	1,50	1,76	3,05	4,05	150
20	2,50	1,93	3,08	4,10	230

Note1 : Values only valid for the application tool specified upwards. The insulator widths are only indicative as they are dependent on the sheath thickness of the wire used

Note2 : Force Control according to IEC 61210 standards.

INSERTION - WITHDRAWAL FORCE / TAKMA - ÇIKARMA KUVVETİ

	1. INSERTION / 1.TAKMA	6. WITHDRAWAL / 6.ÇIKARMA
TS EN 61210	80N max.	18N min.
MESA		

Note : Force Control according to IEC 61210 standards.

Packaging (Pcs)

Ambalaj

6.000 / Cardboard reel.

Pitch (mm)

Hatve

21.00

Drawing

Çizim

Approvals

Onaylar

- RoHS Compliant

- REACH

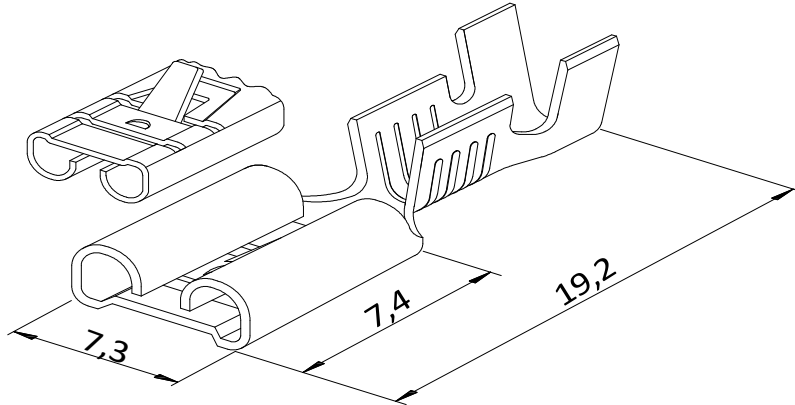

Disclaimer (Sorumluluk sınırı)

The data obtained from the Mesa laboratory trials were made by following the standards set using its own method, cables, equipment and crimping tools. This document has no contractual meaning and is published for informational purposes only. It is subject to change without prior notice. The customer is obliged to check the data given above in his own environment, with his own equipment and production methods.

Mesa laboratuvarı denemelerinden, kendi metodu, kablolar, ekipman ve krimpleme aletleri kullanılarak elde edilen veriler, belirlenen standartlar izlenerek yapılmıştır. Bu belgenin herhangi bir sözleşme anlamı yoktur ve sadece bilgilendirme amacıyla yayınlanmıştır. Önceden haber vermeksizin değiştirilebilir. Müşteri, yukarıda verilmiş olan verileri, kendi ortamında, kendi ekipmanları ve üretim yöntemleri ile kontrol etme sorumluluğuna sahiptir.

Rev.0

Date:23.02.2022